

6GHH HIGH PERFORMANCE HIGH HEAD



Global Pump® High Performance High Head pumps are specifically designed to effectively handle a wide range of liquids in applications such as liquid transfer, wash down, fire protection, fracking and jetting where high heads and pressure are required.

Global Pump High Performance High Head pumps provide a dependable, highly efficient solution. The model 6GHH is capable of achieving maximum flows of 1,440 gpm (327 m³/h) and maximum total head of 748' (228 m) with solids handling up to 0.875" (22.2 mm) in diameter.

The standard 6GHH is powered by a water-cooled, 6-cylinder diesel engine. Alternative drives are available, including other diesel engines or electric motor options.

FEATURES

Global Pump's rugged, heavy duty pumps are engineered specifically for portable application

Non-return valve uses only a single moving part to allow with minimal restriction

Standard engine control panel provides preset emergency shutdown protection and allows the addition of automatic level control

Fully guarded coupling

Pump casings are hydrostatically tested to 50 psig (345 kPa) above the peak casing design pressure

Skid-mounted formats with tie downs, lifting bail, and fork pockets

OPTIONS

Available with a variety of priming systems, including Global's Auto Prime® automatic priming system (compressor-fed venturi priming) or a diaphragm priming system

Mechanical seal with biodegradable (optional) glycol quench allows the pump to start and run dry

Global Pump's Environmental Box separates and silences air exhaust and returns liquid to the pump suction.

Fuel cubes for extended run times and/or remote location as required

Sound attenuated enclosure options

Hose racks, accessory containers and other custom features available as required

Wide range of suction and discharge fittings including Global Pump's own "QD" Quick Disconnect fittings and accessories

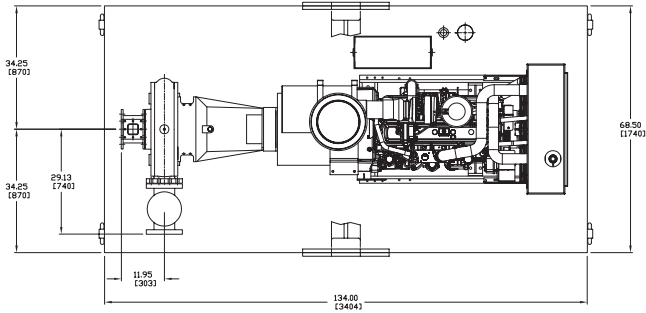
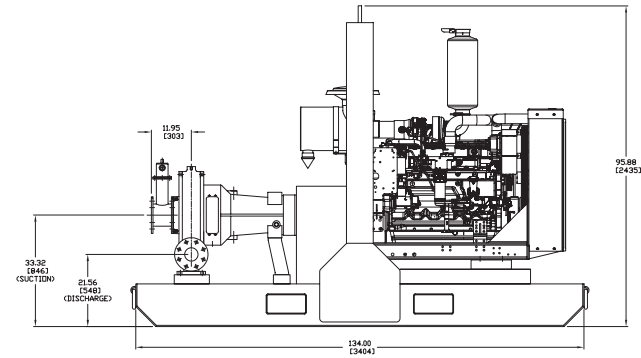

SPECIFICATIONS

Connections	6" x 4" (150 mm x 100 mm) ANSI Flanges
Max Pump Speed	2,000 rpm
Max Flow	1,440 gpm (327 m ³ /h)
Max Head	748' (228 m)
Max Static Priming Lift	28' (8.5 m)
Temperature Limit	160° F (70° C)
Solids Handling Capability	0.875" (22.2 mm)
Max Casing Pressure	300 psig (2068 kPa)
Fuel Cell	325 gallons (1,230 liters)
Dry Weight	8,700 lbs

PUMP MATERIAL

Casing	Cast Steel (CD4MCu is an option)
Impeller	CD4MCu
Bearing Housing	Cast Iron
Bearing Lubrication	Grease
Shaft/Shaft Sleeves	Stainless Steel/ Stainless Steel
Seal	Silicon Carbide on Silicon Carbide
Chassis/Fuel Cell	Steel
Non-Return Valve	Steel

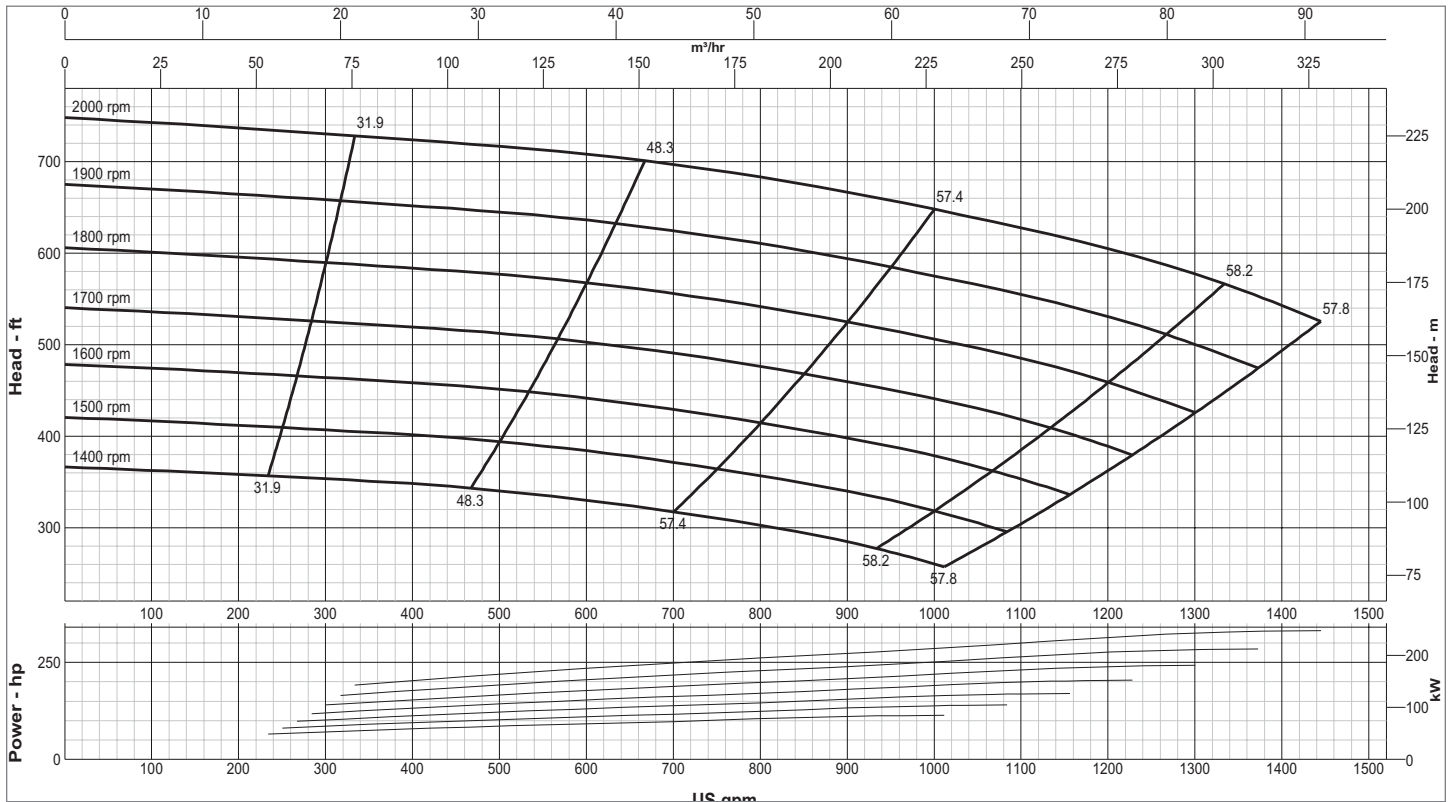

GLOBAL PUMP
 10162 East Coldwater Road, Davison, MI 48423
 Tel: 810.653.4828 Fax: 810.658.0632
1.866.360.PUMP www.globalpump.com