

8GHT
GLOBAL HIGH
PERFORMANCE TRASH



Global Pump® High Performance Trash pumps are specifically designed to effectively handle a wide-range of liquids from water to sewage and sludge that can contain solids and other material.

Global Pump High Performance Trash pumps provide a dependable, highly efficient solution. The model 8GHT is capable of achieving maximum flows of 4,550 gpm (1,033 m³/h) and maximum total head of 261' (79.6 m) while handling solids up to 4" (101.6 mm) in diameter.

The standard 8GHT is powered by a water-cooled, 6-cylinder diesel engine. Alternative drives are available, including other diesel engines or electric motor options.

FEATURES	OPTIONS
Global Pump's rugged, heavy duty pumps are engineered specifically for portable application	Available with a variety of priming systems, including Global's Auto Prime® automatic priming system (compressor-fed venturi priming) or a diaphragm priming system
Non-return valve uses only a single moving part to allow with minimal restriction	Mechanical seal with biodegradable (optional) glycol quench allows the pump to start and run dry
Standard engine control panel provides preset emergency shutdown protection and allows the addition of automatic level control	Global Pump's Environmental Box separates and silences air exhaust and returns liquid to the pump suction.
Fully guarded coupling	Fuel cubes for extended run times and/or remote location as required
Pump casings are hydrostatically tested to 50 psig (345 kPa) above the peak casing design pressure	Sound attenuated enclosure options
Highway trailer with integral fuel cell/chassis, lights, fenders, tie downs, lifting bail, front and rear jacks. Trailer brakes can be offered as required	Skid-mounted formats with tie downs, lifting bail, and fork pockets
	Hose racks, accessory containers and other custom features available as required
	Wide range of suction and discharge fittings including Global Pump's own "QD" Quick Disconnect fittings and accessories

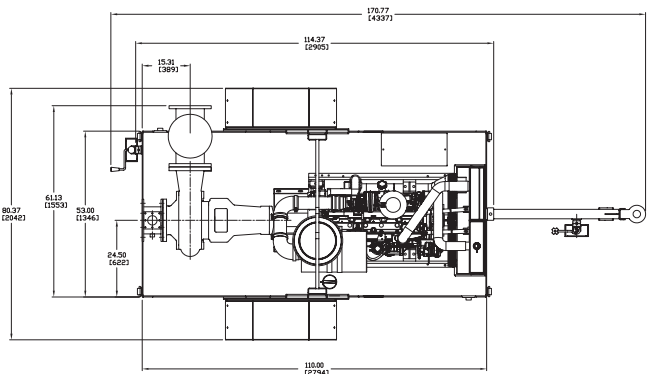
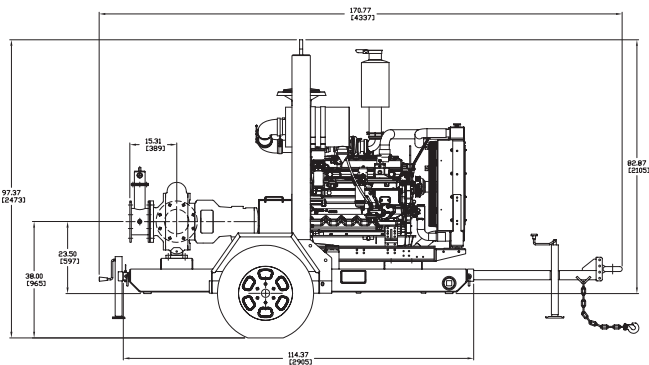

SPECIFICATIONS

Connections	8" (200 mm) ANSI Flanges
Max Pump Speed	2,000 rpm
Max Flow	4,550 gpm (1,033 m ³ /h)
Max Head	261' (79.6 m)
Max Static Priming Lift	28' (8.5 m)
Temperature Limit	160° F (70° C)
Solids Handling Capability	4" (101.6 mm)
Max Casing Pressure	125 psig (862 kPa)
Fuel Cell	150 gallons (565 liters)
Dry Weight	6,300 lbs

PUMP MATERIAL

Casing	Cast Iron (CD4MCu is an option)
Impeller	Cast Iron (CD4MCu is an option)
Bearing Housing	Cast Iron
Bearing Lubrication	Grease
Shaft/Shaft Sleeve	Steel/Stainless Steel
Seal	Silicon Carbide on Silicon Carbide
Chassis/Fuel Cell	Steel
Non-Return Valve	Nitrile Fitted Cast Iron

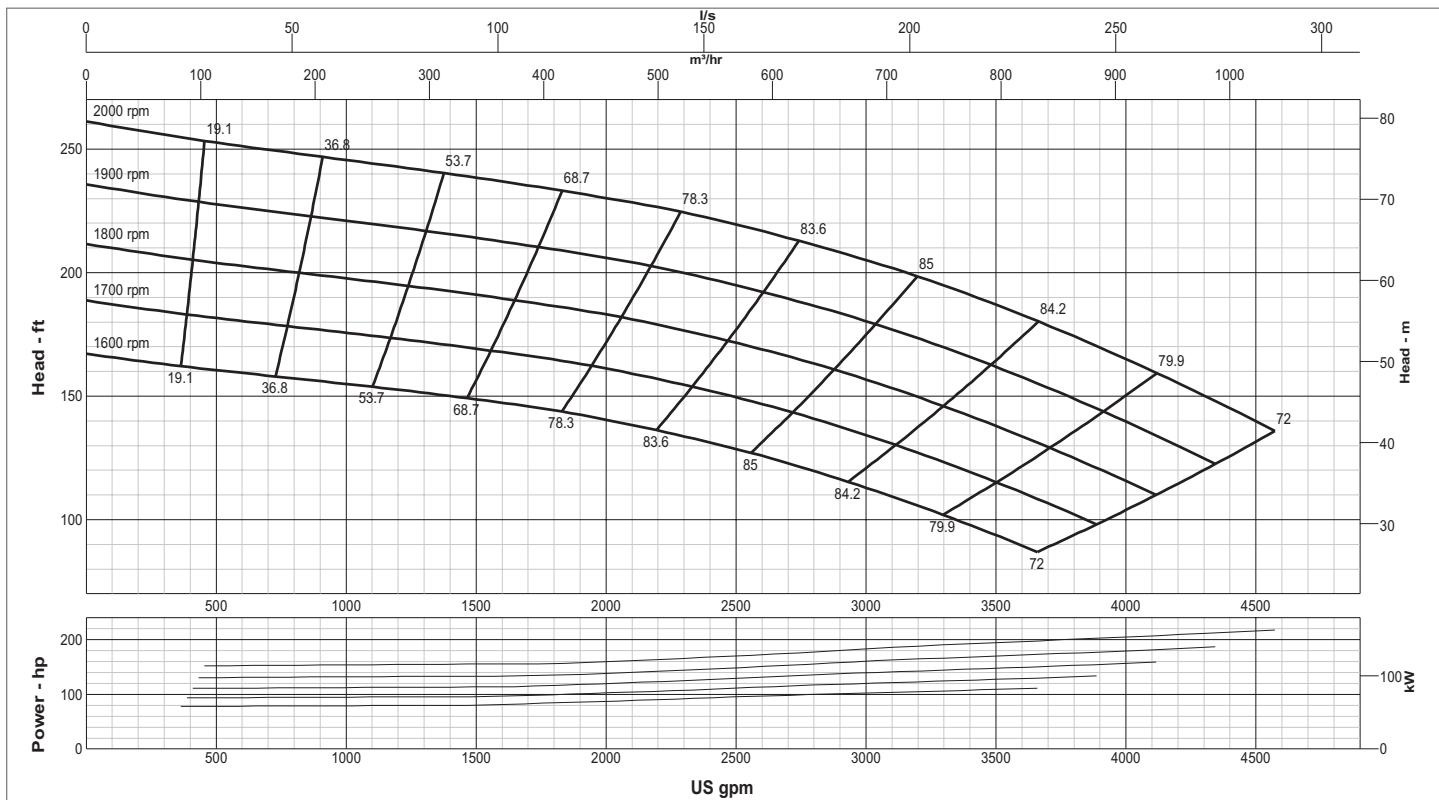

GLOBAL PUMP
 10162 East Coldwater Road, Davison, MI 48423
 Tel: 810.653.4828 Fax: 810.658.0632
1.866.360.PUMP www.globalpump.com